

Solenoid valves for air VR

Technical Information · GB

3 Edition 05.12



- Quick or slow opening and closing
- Flow rate can be restricted
- Robust design for a long service life
- Suitable for high-duty cycling
- Internal bypass orifice can be selected
- EC type-tested and certified
- Certified by Gosstandart pursuant to GOST-TR



Contents

- Solenoid valves for air VR 1
- Contents 2
- 1 Application 3
 - 1.1 Examples of application 4
- 2 Certification 5
- 3 Function 6
 - 3.1 Solenoid valve for air VR..N, quick opening and closing 6
 - 3.2 Solenoid valve for air VR..R, slow opening and closing 7
 - 3.3 Solenoid valve for air VR..L, slow opening and quick closing 7
- 4 Flow rate 8
 - 4.1 Bypass flow rate 8
- 5 Selection 9
 - 5.1 VR 25–65 9
 - 5.1.1 Type code 9
- 6 Project planning information 10
 - 6.1 Installation 10
 - 6.2 Wiring 10
- 7 Accessories 11
 - 7.1 Position indicator 11
- 8 Technical data 12
 - 8.1 Dimensions of VR 25 to 40/32 13
 - 8.2 Dimensions of VR 40 to 65 14
- 9 Maintenance cycles 15
- Feedback 16
- Contact 16

1 Application

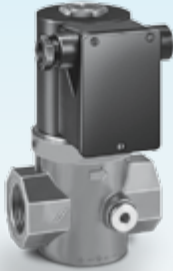

*VR..R..N
quick opening/closing*



*VG..R..R
slow opening/closing*



*VG..F..N
quick opening/closing*

Robust solenoid valves for air VR for staged control of industrial burners in cold-air operating mode. For heavy duty use in industrial heat generation.

1.1 Examples of application

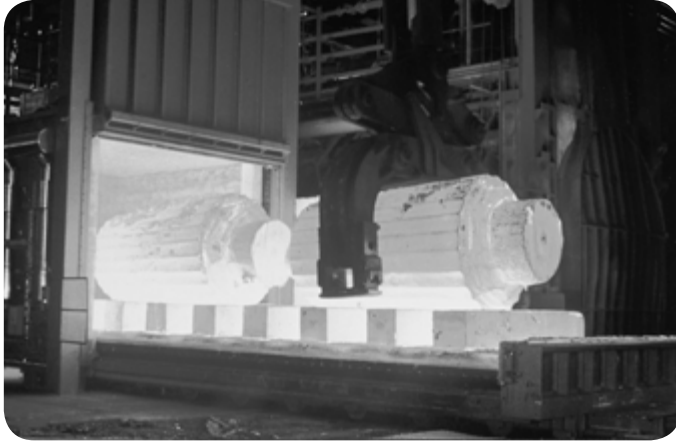

Metallurgical industry: forging furnace

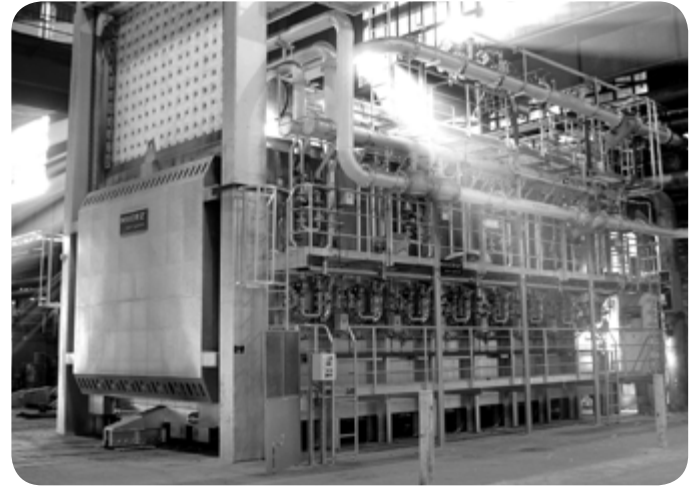

Ceramics industry: intermittent shuttle kiln



Aluminium industry: smelting furnace

2 Certification

EC type-tested and certified



Meets the requirements of the

- Low Voltage Directive (2006/95/EC),
- EMC Directive (2004/108/EC).

Approval for Russia



Certified by Gosstandart pursuant to GOST-TR.

Approved by Rostekhnadzor (RTN).

Scan of the approval for Russia (RUS) – see www.docuthek.com → Elster Kromschroder → Products → 03 Valves and butterfly valves → Solenoid valves for air VR → Kind of document: Certificate → VG B00071 (nationales Zertifikat Russland) (RUS)

3 Function

3.1 Solenoid valve for air VR..N, quick opening and closing

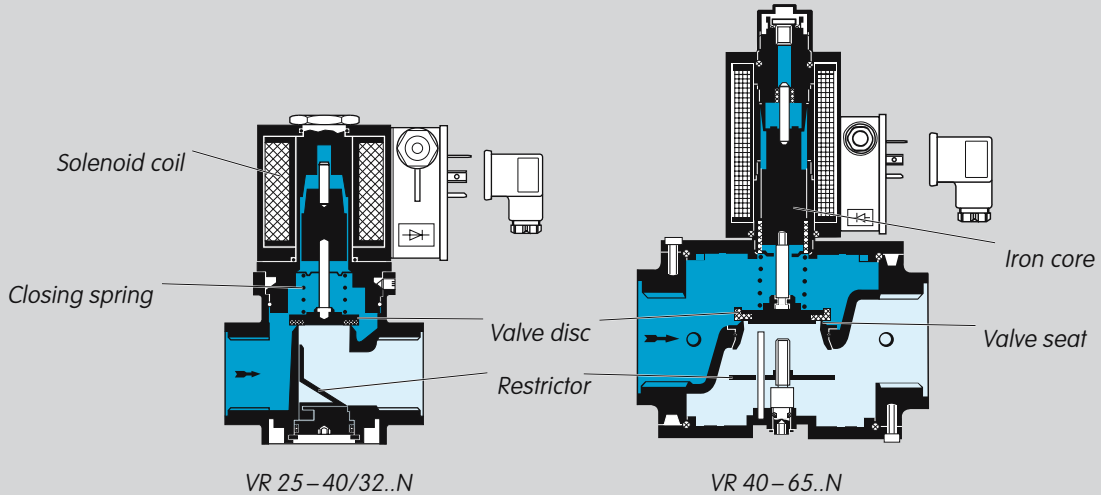

The solenoid valve for air VR is closed when de-energized.

Opening: the applied AC voltage is rectified and generates a powerful magnetic field in the solenoid coil. The magnetic field attracts the iron core and lifts the valve disc from the valve seat, acting against the effective inlet pressure and the closing spring force. The solenoid valve for air VR opens and the air supply is released.

Closing: when the voltage is disconnected, the magnetic field collapses and within 1 s, the closing spring pushes the iron core with valve disc back onto the valve seat. The solenoid valve for air VR closes and the air supply is stopped.

The flow rate can be varied by a restrictor in the housing bottom.

Turn clockwise to reduce the flow rate.

Turn anti-clockwise to increase the flow rate.

3.2 Solenoid valve for air VR..R, slow opening and closing

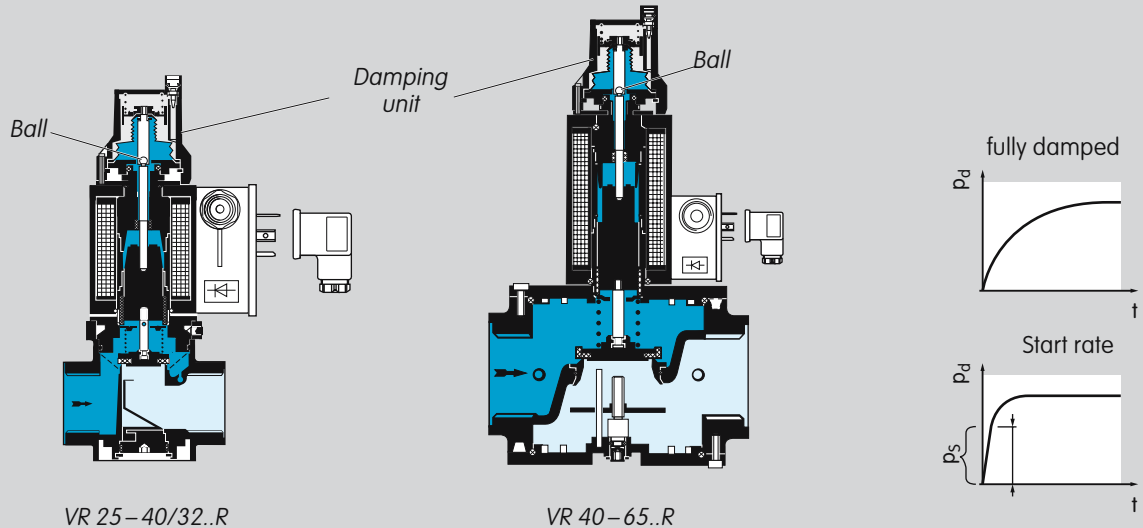

The solenoid valve for air VR..R opens and closes within 4 s. The stem of the iron core is connected to the damping spindle via a ball. This connection ensures that the closing movement is damped.

3.3 Solenoid valve for air VR..L, slow opening and quick closing

With start rate: the solenoid valve for air opens with a quick initial lift and then continues slowly until it is fully open.

By turning the damping unit, the start rate can be set between 0 and 70% of the flow rate:

Turning it clockwise will decrease the start rate and turning it anti-clockwise will increase the start rate.

No start rate is set at the factory.

The VR..L closes within 1 s.

4 Flow rate

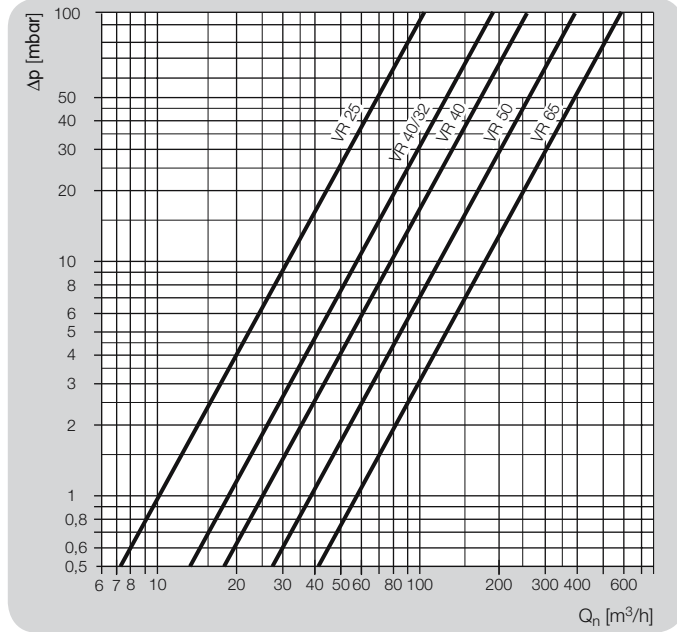

4.1 Bypass flow rate

The solenoid valve for air VR is available with a bypass orifice in the valve housing on request.

The diameter of the bypass orifice depends on the supply pressure and air requirement.

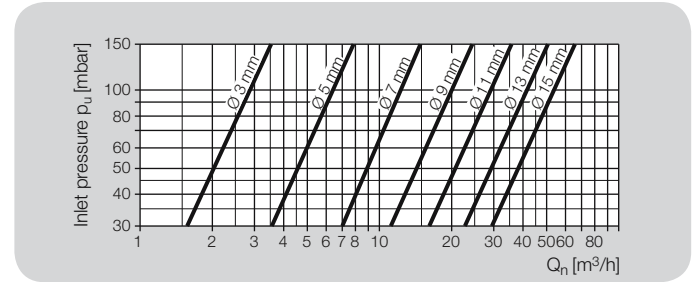

5 Selection

5.1 VR 25–65

Typ	R	F	01	N L R	T Q K	3 6	1 3	D	2-15
VR 25	●		●	● ○ ○	● ○ ○	● ○	●	●	○
VR 40/32	●		●	● ○ ○	● ○ ○	● ○	●	●	○
VR 40	●		●	● ○ ○	● ○ ○	● ○	●	●	○
VG 50	●	●	●	● ○ ○	● ○ ○	● ○		●	○
VG 65		●	●	● ○ ○	● ○ ○	● ○		●	○

● = standard

○ = optional

Order example

VR 40R01NT33D10

5.1.1 Type code

Code	Description
VR	Solenoid valve for air
25–65	Nominal diameter
R	Rp internal thread
F	Flange to ISO 7005
01	p _u max. 150 mbar
N	Quick opening, quick closing
L	Slow opening, quick closing
R	Slow opening, slow closing
T	Mains voltage 220/240 V AC, 50/60 Hz
Q	Mains voltage 120 V AC, 50/60 Hz
K	Mains voltage 24 V DC
3	Terminal connection box, IP 54
6	Electrical connection via standard socket
1	Screw plug at the inlet
3	Screw plug at the inlet and outlet
D	With flow adjustment
2–15*	Bypass [mm]*

* If "none", this number is omitted.

6 Project planning information

6.1 Installation

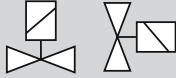

Installation position: black solenoid actuator in the vertical upright position or tilted up to the horizontal, not upside down.

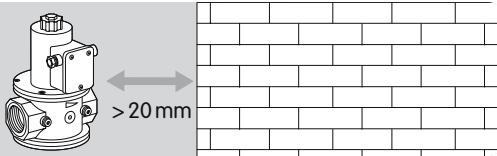

The solenoid valve for air VR must not be in contact with masonry. Minimum clearance 20 mm.

Do not store or install the unit in the open air.

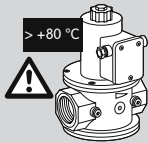

The solenoid body heats up during operation depending on ambient temperature and voltage.

6.2 Wiring

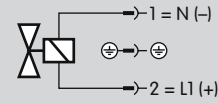

Wiring to EN 60204-1.

7 Accessories

7.1 Position indicator



Regardless of nominal diameter, the solenoid valve for air VR can be subsequently fitted with a micro switch for the “closed” or “not closed” signal, depending on the wiring of the contact sequence.

Cable gland: PG 11, on request: with socket to ISO 4400.

Connection ratings:

12 – 24 V AC/DC

$I = 0.1 \text{ A}$, $\cos \varphi = 1$,

$I = 0.05 \text{ A}$, $\cos \varphi = 0.6$.

250 V AC

$I = 1 \text{ A}$, $\cos \varphi = 0.6$,

$I = 5 \text{ A}$, $\cos \varphi = 1$.

If the micro switch has switched a voltage $> 24 \text{ V}$ and a current $> 0.1 \text{ A}$ once, the gold plating on the contacts will have been burnt through. The switch can then only be operated at this power rating or higher power rating.

8 Technical data

Medium: clean air. The air must be dry in all temperature conditions and must not contain condensate.

Opening time:

VR..N: quick opening: 0.5 s.

VR..L: slow opening: 4 s.

VR..R: slow opening: 4 s.

Closing time:

VR..N: quick closing: < 1 s.

VR..L: quick closing: < 1 s.

VR..R: slow closing: 4 s.

Ambient temperature: -20 to +60°C.

Storage temperature: -20 to +40°C.

Mains voltage:

220/240 V AC, +10/-15%, 50/60 Hz,

120 V AC, +10/-15%, 50/60 Hz,

24 V DC, +10/-15%.

Electrical connection of VR 25 – 40/32:

- plug with socket to EN 175301-803,
- cable gland: PG 11,
- connection terminal: 2.5 mm².

Electrical connection of VR 40 – 65:

- plug with socket to EN 175301-803,
- cable gland: PG 13.5,
- connection terminal: 2.5 mm².

Enclosure: IP 54.

Duty cycle: 100%.

Power factor of the solenoid coil: $\cos \varphi = 1$.

Solenoid coil insulation: class F insulating material.

Switching frequency:

version without damping unit: any,
version with damping unit: with fully operational damping unit, max. 6 switching operations per minute.

Valve housing: aluminium,
valve disc: Perbunan.

Internal thread: Rp to ISO 7-1.

Flange: ISO 7005 (DN 65 to DIN 2501), PN 16.

8.1 Dimensions of VR 25 to 40/32

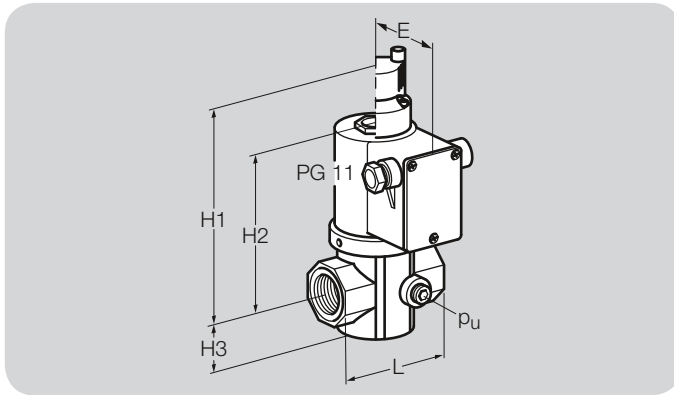

Data table

Typ	Dimensions							$p_{U \text{ max.}}$ mbar	Q $\Delta p = 1 \text{ mbar}$ m ³ /h Air	kv m ³ /h	P		Weight kg
	DN	Connection	L mm	H1 mm	H2 mm	H3 mm	E mm				220 V~ 120 V~ 24 V=	240 V~	
VR 25R01..	25	Rp 1	91	175	126	33	66	150	10	4.3	31	37	2.1
VR 40/32R01..	40	Rp 1½	128	194	145	39	66	150	18	20.5	31	37	2.4

8.2 Dimensions of VR 40 to 65

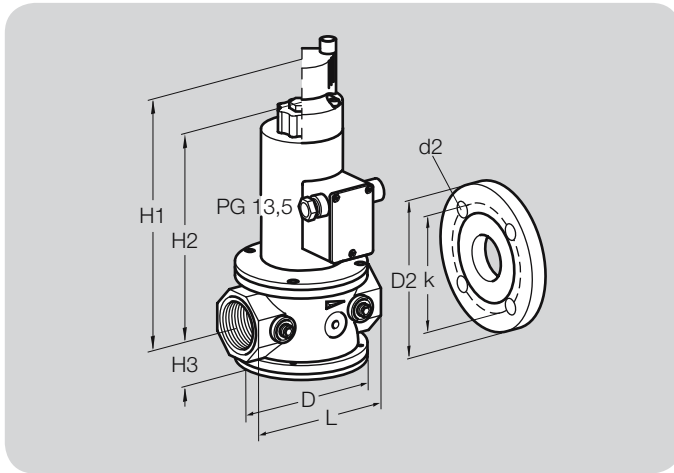

Data table

Type	Dimensions							Flange		Drilling		p _{U max.} mbar	Q Δp = 1 mbar m ³ /h Air	kv m ³ /h	P		Wgh. kg
	DN	Connetion	L mm	D mm	H1 mm	H2 mm	H3 mm	D2 mm	k mm	d2 mm	No.				220 V~ 120 V~ 24 V=	240 V~	
VR 40R01..	40	Rp 1½	150	129	280	210	51	–	–	–	–	150	24	27.3	67	75	5.8
VR 40F01..	40	40	150	129	280	210	51	150	110	18	4	150	24	15.4	67	75	7.8
VR 50R01..	50	Rp 2	180	157	291	221	62	–	–	–	–	150	37	42.1	67	75	6.3
VR 50F01..	50	50	230	157	291	221	62	165	125	18	4	150	37	42.1	67	75	8.3
VR 65R01..	65	Rp 2½	218	183	303	233	74	–	–	–	–	150	57	64.8	73	86	9.1
VR 65F01	65	65	290	183	303	233	74	185	145	18	4	150	57	73	86	86	11.1

A horizontal dotted line consisting of small yellow dots, extending across the top of the page.

9 Maintenance cycles

At least once per year.

Feedback

Finally, we are offering you the opportunity to assess this "Technical Information (TI)" and to give us your opinion, so that we can improve our documents further and suit them to your needs.



Clarity

- Found information quickly
- Searched for a long time
- Didn't find information
- What is missing?
- No answer

Comprehension

- Coherent
- Too complicated
- No answer

Scope

- Too little
- Sufficient
- Too wide
- No answer

Use

- To get to know the product
- To choose a product
- Planning
- To look for information

Navigation

- I can find my way around
- I got "lost"
- No answer

My scope of functions

- Technical department
- Sales
- No answer

Remarks

(Adobe Reader 7 or higher required)
www.adobe.com



elster
Kromschroeder

Contact

Elster GmbH
Postfach 2809 · 49018 Osnabrück
Strothweg 1 · 49504 Lotte (Büren)
Germany

T +49 541 1214-0
F +49 541 1214-370
info@kromschroeder.com
www.kromschroeder.com
www.elster.com

The current addresses of our international agents are available on the Internet:
www.kromschroeder.de/index.php?id=718&L=1

We reserve the right to make technical modifications in the interests of progress.
Copyright © 2012 Elster Group
All rights reserved.