

Solenoid valves for gas VG

Technical Information · GB

3 Edition 01.15



- Safety valves for gas
- Quick or slow opening with adjustable start gas rate
- Flow rate can be restricted
- Robust design for a long service life
- Suitable for high-duty cycling
- EC type-tested and certified
- AGA approved



krom
schroder

Contents

Solenoid valves for gas VG	1	9 Maintenance cycles	21
Contents	2	Feedback	22
1 Application	3	Contact	22
1.1 Examples of application	4		
2 Certification	5		
3 Function	6		
3.1 Solenoid valve for gas VG..N, quick opening	6		
3.2 Solenoid valve for gas VG..L, slow opening	7		
3.3 Animation VG..R..N, quick opening	8		
3.4 Animation VG..R..L, slow opening	9		
4 Flow rate	10		
4.1 Valves for low inlet pressures, $p_U < 1$ bar	10		
4.1.1 Calculating the nominal size	10		
4.2 Valves for higher inlet pressures, $p_U \geq 1$ bar	11		
4.2.1 Calculating the nominal size	11		
4.3 k_v value	12		
5 Selection	13		
5.1 VG 6 – 15/10	13		
5.1.1 Type code	13		
5.2 VG 15 – 65	14		
5.2.1 Type code	14		
6 Project planning information	15		
6.1 Installation	15		
6.2 Wiring	15		
7 Accessories	16		
7.1 Pressure test point	16		
7.2 Plug with socket	16		
8 Technical data	17		
8.1 Dimensions of VG 6 to 15/10	18		
8.2 Dimensions of VG 15 to 40/32	19		
8.3 Dimensions of VG 40 to 65	20		

1 Application



VG 6 to 15/10

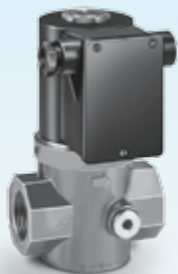

*VG..R..N
quick opening*



*VG..R..L
slow opening*



*VG..F..N
quick opening*

Robust gas solenoid valves VG for safeguarding and controlling the air and gas supply to gas burners and gas appliances. For heavy duty use in gas control and safety systems in industrial heat generation.

1.1 Examples of application



Metallurgical industry: forging furnace

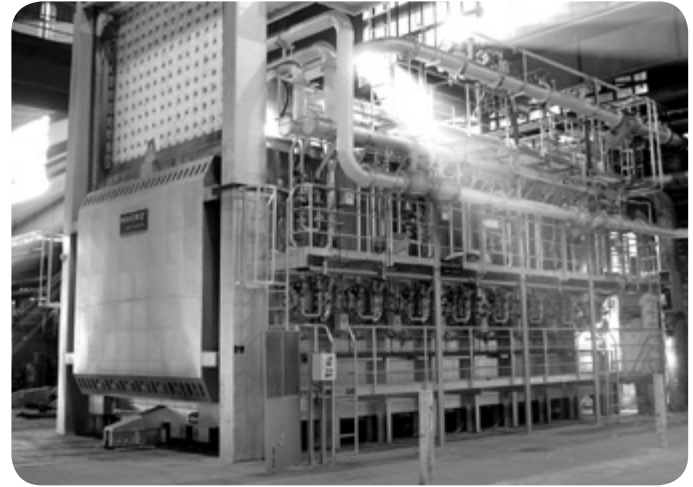

Ceramics industry: intermittent shuttle kiln



Aluminium industry: smelting furnace

2 Certification

EU certified pursuant to



- Gas Appliances Directive (2009/142/EC) in conjunction with EN 13611 and EN 161

Meets the requirements of the

- Low Voltage Directive (2006/95/EC),
- EMC Directive (2004/108/EC).

AGA approved



Australian Gas Association, Approval No.: 3968

www.aga.asn.au/product_directory

Approval for Russia



The product VG meets the technical specifications of the Eurasian Customs Union (the Russian Federation, Belarus, Kazakhstan).

3 Function

3.1 Solenoid valve for gas VG..N, quick opening

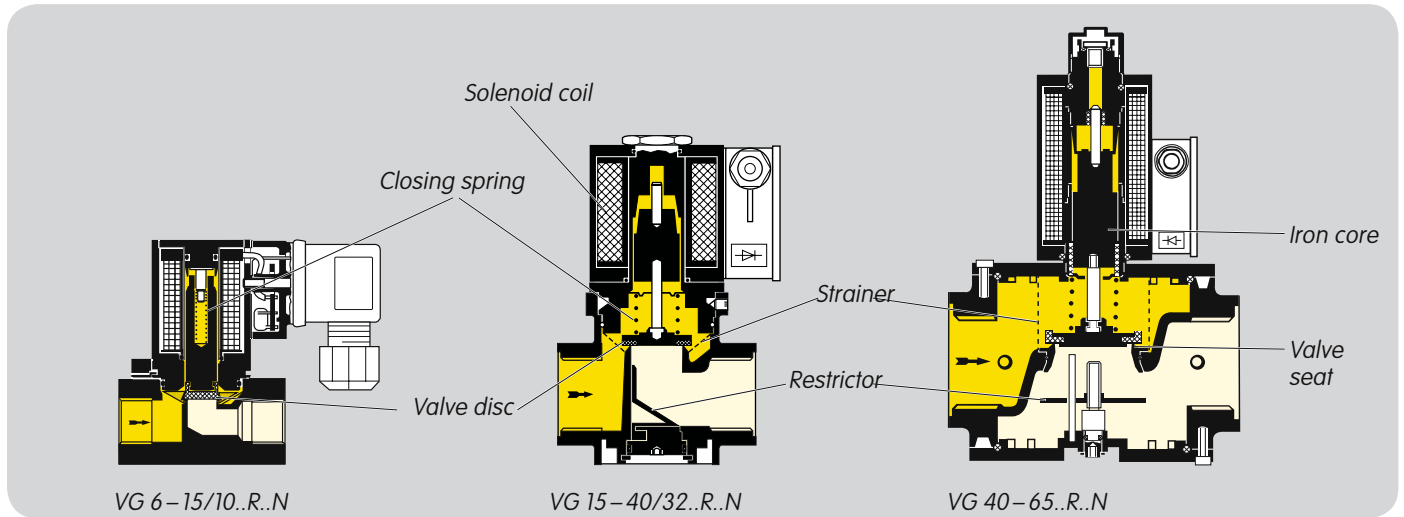

The gas solenoid valve VG is closed when de-energized.

Opening: the applied AC voltage is rectified and generates a powerful magnetic field in the solenoid coil. The magnetic field attracts the iron core and lifts the valve disc from the valve seat, acting against the effective inlet pressure and the closing spring force. The gas solenoid valve VG opens and the gas supply is released.

Closing: when the voltage is disconnected, the magnetic field collapses and within 1 s, the closing spring pushes the iron core with valve disc back onto the valve seat. The gas solenoid valve VG closes and the gas supply is stopped.

The strainer in the inlet of the gas solenoid valve prevents deposits of dirt particles on the valve seat. The pressure loss through the strainer is very low. The flow rate can be varied by a restrictor in the housing bottom

VVG 15-40/32..M

In the version without non-ferrous metals, the solenoid valves are suitable for operation with biologically produced methane.

VG 15-65..DMVZ

The valves do not contain non-ferrous metals and a rolling diaphragm prevents dirt deposits in the guide tube.

3.2 Solenoid valve for gas VG..L, slow opening

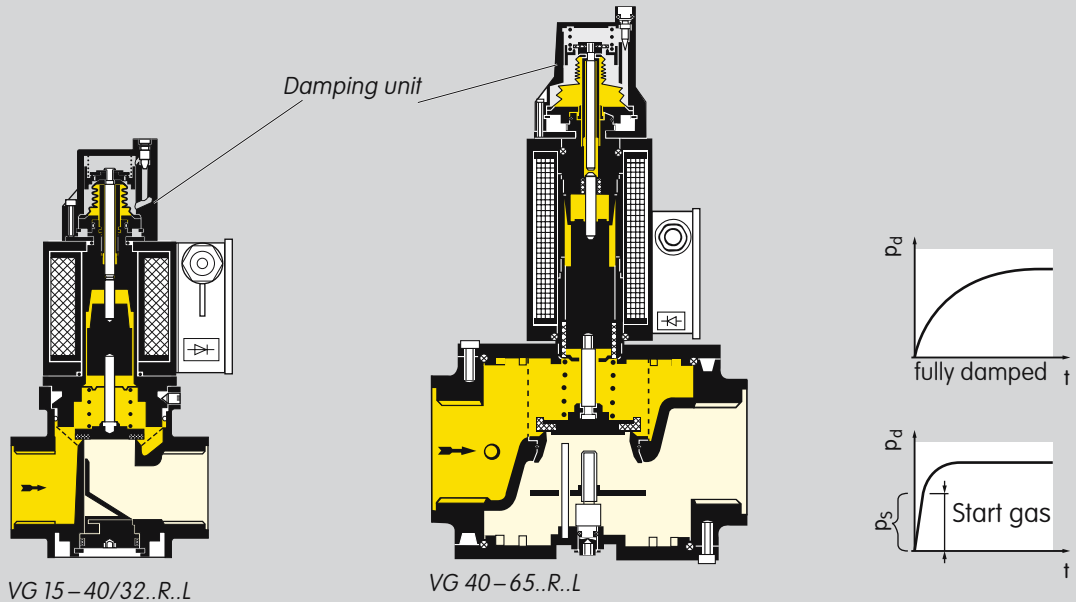

The gas solenoid valve VG..L opens within 10 s.

With start gas rate: the gas solenoid valve opens with a quick initial lift and then continues slowly until it is fully open. A start gas rate is required, for example if a tightness control TC is to be used.

By turning the damping unit, the start gas rate can be set between 0 and 70% of the flow rate (at $\Delta p = 1$ mbar):

Turning it clockwise will decrease the start gas rate and turning it anti-clockwise will increase the start gas rate.

No start gas rate is set at the factory.

3.3 Animation VG..R..N, quick opening

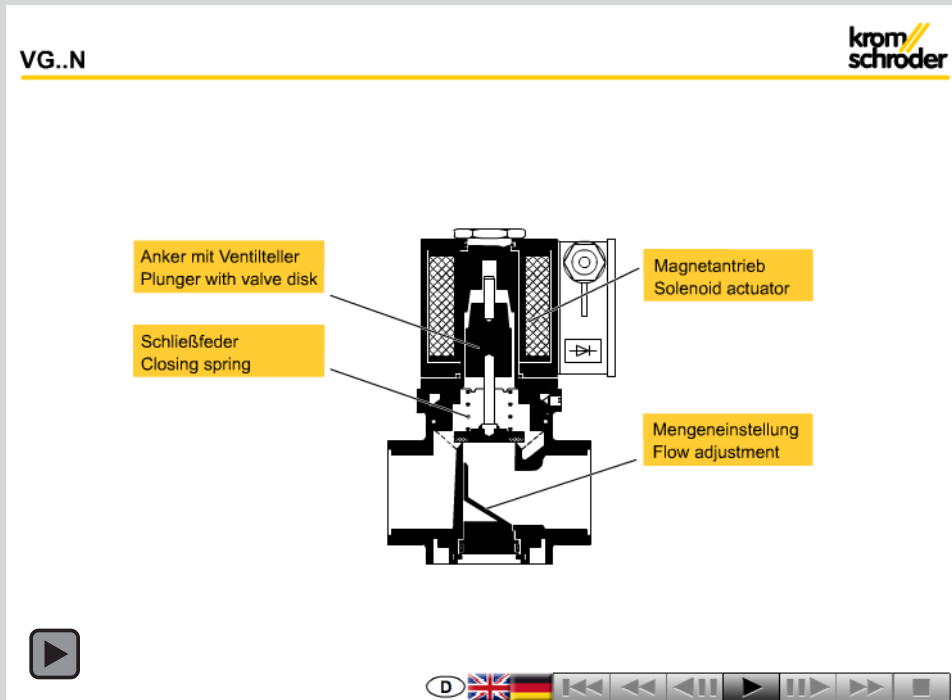

The interactive animation shows the function of the gas solenoid valve VG..N, quick opening.

Click on the picture. The animation can be controlled using the control bar at the bottom of the window (as on a DVD player).

To play the animation, you will need Adobe Reader 9 or a newer version. If you do not have Adobe Reader on your system, you can download it from the Internet.

Go to www.adobe.com, click on "Adobe Reader" at the bottom of the page and follow the instructions.

If the animation does not start to play, you can download it from the document library (Docuthek) as an independent application.

3.4 Animation VG..R..L, slow opening

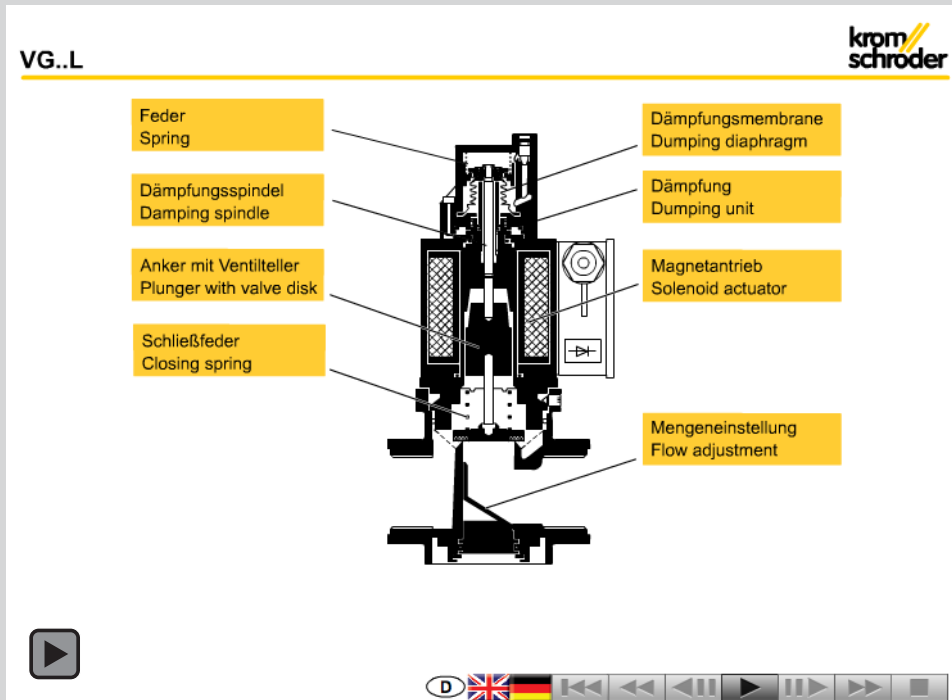

The interactive animation shows the function of the gas solenoid valve VG..L, slow opening.

Click on the picture. The animation can be controlled using the control bar at the bottom of the window (as on a DVD player).

To play the animation, you will need Adobe Reader 9 or a newer version. If you do not have Adobe Reader on your system, you can download it from the Internet.

Go to www.adobe.com, click on "Adobe Reader" at the bottom of the page and follow the instructions.

If the animation does not start to play, you can download it from the document library (Docuthek) as an independent application.

4 Flow rate

4.1 Valves for low inlet pressures, $p_U < 1$ bar

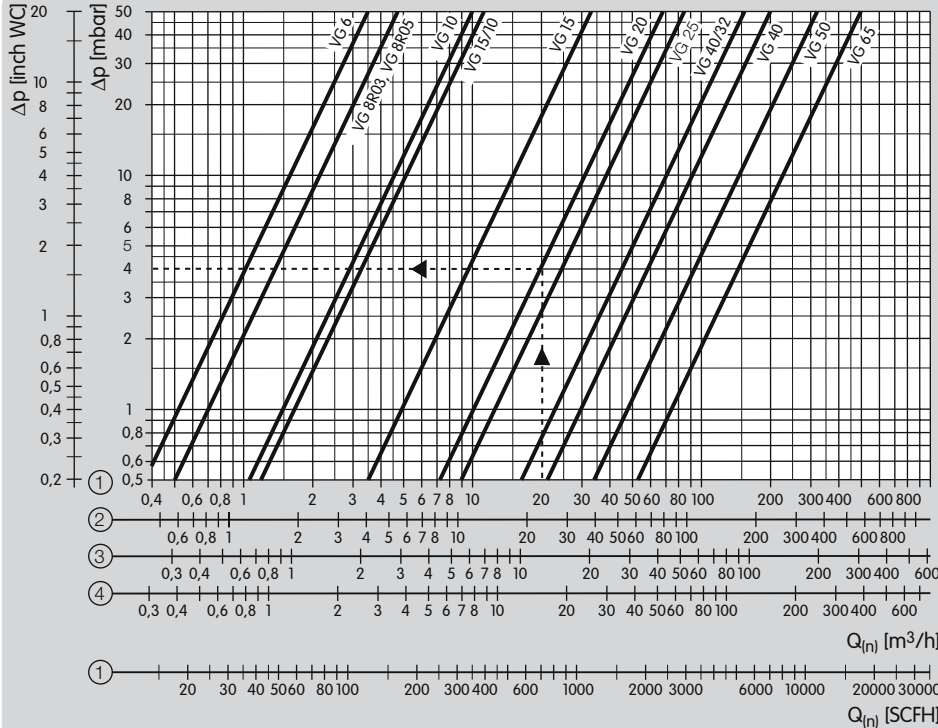

Reading instructions: when determining the pressure loss, operating cubic metres must be entered. Then the pressure loss Δp read must be multiplied by the absolute pressure in bar (positive pressure + 1) to account for the change in the medium's density.

Example:

inlet pressure p_U (positive pressure) = 200 mbar,
 gas type: natural gas,
 operating flow rate $Q_b = 20 \text{ m}^3/\text{h}$,
 Δp from diagram = 4 mbar,
 $\Delta p = 4 \text{ mbar} \times (1 + 0.2) = 4.8 \text{ mbar}$ on the solenoid valve VG 20.

4.1.1 Calculating the nominal size

metric imperial

Enter density
 Flow rate Q (standard)
 Inlet pressure p_U
 Δp_{max}
 Medium temperature
 Flow rate Q (operation)
 Product Δp v

4.2 Valves for higher inlet pressures, $p_U \geq 1$ bar

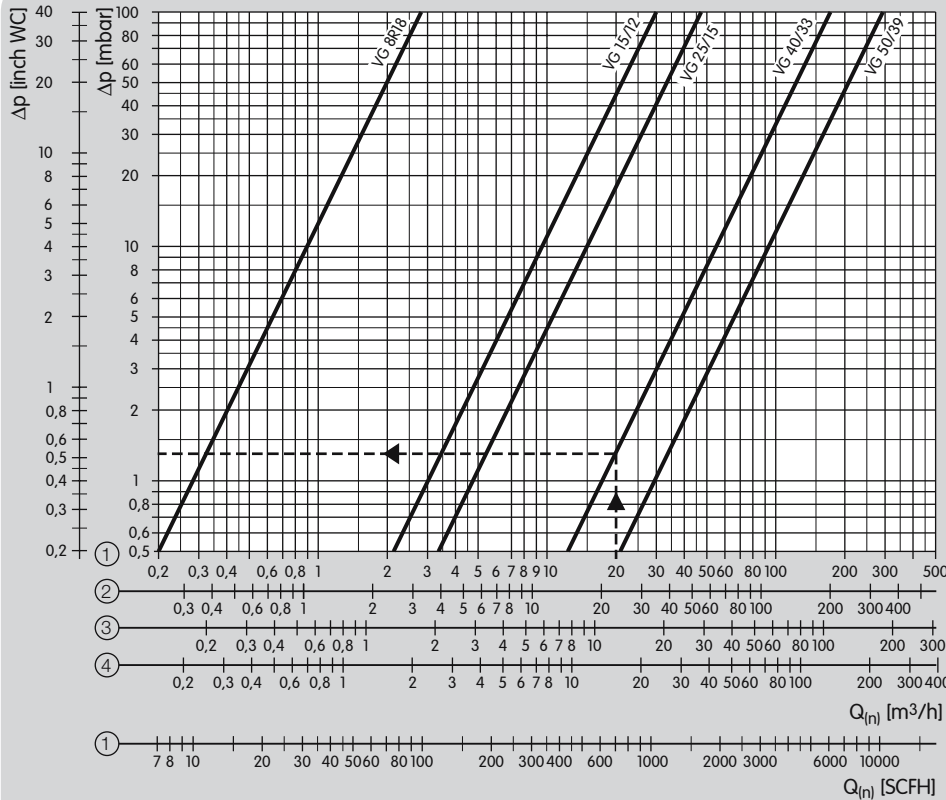

- ① = natural gas ($\rho = 0.80 \text{ kg/m}^3$)
- ② = town gas ($\rho = 0.64 \text{ kg/m}^3$)
- ③ = LPG ($\rho = 2.01 \text{ kg/m}^3$)
- ④ = air ($\rho = 1.29 \text{ kg/m}^3$)

Reading instructions: when determining the pressure loss, operating cubic metres must be entered. Then the pressure loss Δp read must be multiplied by the absolute pressure in bar (positive pressure + 1) to account for the change in the medium's density.

Example:

inlet pressure p_U (positive pressure) = 200 bar,
 gas type: natural gas,
 operating flow rate $Q_b = 20 \text{ m}^3/\text{h}$,
 Δp from diagram = 1.25 mbar,
 $\Delta p = 1.25 \text{ mbar} \times (1 + 0.2) = 1.5 \text{ mbar}$ on the solenoid valve VG 40/33.

4.2.1 Calculating the nominal size

metric	imperial
Enter density	
Flow rate Q (standard)	
Inlet pressure p_U	
Δp_{max}	
Medium temperature	
Flow rate Q (operation)	

Product	Δp	v
---------	------------	---

4.3 k_v value

The size and nominal flange diameter is determined using the flow rate diagram or by calculation using the k_v value.

$Q_{(n)}$ = Flow rate (standard state) [m³/h]

k_v = Valve coefficient

Δp = Pressure loss [bar]

p_d = Outlet pressure (absolute) [bar]

ρ_n = Density [kg/m³] (air 1.29, natural gas 0.80, propane 2.01, butane 2.71)

T = Medium temperature (absolute) [K]

$$k_v = \frac{Q_{(n)}}{514} \cdot \sqrt{\frac{\rho_n \cdot T}{\Delta p \cdot p_d}} \quad Q_{(n)} = 514 \cdot k_v \cdot \sqrt{\frac{\Delta p \cdot p_d}{\rho_n \cdot T}}$$

$$\Delta p = \left(\frac{Q_{(n)}}{514 \cdot k_v} \right)^2 \cdot \frac{\rho_n \cdot T}{p_d}$$

$p_U < 1$ bar

VG	k_v m ³ /h
VG 6	0.47
VG 8	0.64
VG 10	1.32
VG 15/10	1.53
VG 15	4.5
VG 20	9.1
VG 25	11.5
VG 40/32	21.0
VG 40	27.0
VG 50	43.0
VG 65	67.0

$p_U \geq 1$ bar

VG	k_v m ³ /h
VG 8R18	0.26
VG 15/12R18	2.8
VG 25/15R18	4.4
VG 40/33..10	16.1
VG 50/39..10	27.0

Example

We want to find the size and nominal flange diameter for a gas solenoid valve VG.

We have the maximum flow rate $Q_{(n) \max}$, the inlet pressure p_U and the natural gas temperature T .

$$Q_{(n) \max} = 60 \text{ m}^3/\text{h}$$

$$p_U = 70 \text{ mbar} = 0.07 \text{ bar} \rightarrow$$

$$p_U \text{ absolute} = 0.07 \text{ bar} + 1 \text{ bar} = 1.07 \text{ bar}$$

$$\Delta p_{\max} = 0.01 \text{ bar (desired)}$$

$$p_d \text{ absolute} = p_U \text{ absolute} - \Delta p_{\max}$$

$$p_d \text{ absolute} = 1.07 \text{ bar} - 0.01 \text{ bar} = 1.06 \text{ bar}$$

$$T = 27 \text{ }^\circ\text{C} \rightarrow$$

$$T_{\text{absolute}} = 27 + 273 \text{ K} = 300 \text{ K}$$

$$k_v = \frac{60}{514} \cdot \sqrt{\frac{0.83 \cdot 300}{0.01 \cdot 1.06}} = 17.9$$

The gas solenoid valve is selected using the next higher k_v value (see table): VG 40/32.

5 Selection

5.1 VG 6–15/10

Type	R	K	01	03	05	18	T	Q	K	5	6	6L	G	V
VG 6		●		●	○		●	○	○	○	●	○	○	
VG 6	●				●		●	○	○	○	●	○		
VG 8	●			●	○	○	●	○	○	○	●	○	○	○
VG 10	●		●				●	○	○	○	●	○		
VG 15/10	●		●				●	○	○	○	●	○	○	

● = standard, ○ = optional

Order example

VG 8R03T6

5.1.1 Type code

Code	Description
VG	Gas solenoid valve
6, 8, 10, 15/10	Nominal size
K	Double-cone olive for 8 mm tube loosely enclosed
R	Rp internal thread
01	p_U max. 100 mbar
03	p_U max. 360 mbar
05	p_U max. 500 mbar
18	p_U max. 1.8 bar
T	Mains voltage: 220/240 V AC, 50/60 Hz
Q	Mains voltage: 120 V AC, 50/60 Hz
K	Mains voltage: 24 V DC
5	Connection via standard plug without socket
6	Connection via standard plug and socket
6L	Connection via standard plug and socket with lamp
G	Low-noise
V	Viton valve disc seal

5.2 VG 15–65

Type	R	F	02	03	10	18	N	L	T	Q	K	3	1	3	D	M	V	Z
VG 15	●		●	○			●	○	●	○	○	●	●		●	○	○	○
VG 15/12	●					●	●		●	○	○	●	●					
VG 20	●		●	○			●	○	●	○	○	●	●		●	○	○	○
VG 25	●		●	○			●	○	●	○	○	●	●		●	○	○	○
VG 25/15	●					●	●		●	○	○	●	●					
VG 40/32	●	●					●	○	●	○	○	●	●		●	○	○	○
VG 40	●		●				●	○	●	○	○	●	●	●	●	●	●	●
VG 40/33	●	●				●	●		●	○	○	●	●					
VG 50	●	●			●		●	○	●	○	○	●	●		●	●	●	●
VG 50/39	●	●				●	●		●	○	○	●	●					
VG 65		●	●				●	○	●	○	○	●	●		●	●	●	●

● = standard, ○ = optional

Order example

VG 40R03NT33DMVZ

5.2.1 Type code

Code	Description
VG	Gas solenoid valve
15–65	Nominal size
R	Rp internal thread
F	Flange to ISO 7005
02	p_U max. 200 mbar
03	p_U max. 360 mbar
10	p_U max. 1 bar
18	p_U max. 1.8 bar
L	Slow opening, quick closing
N	Quick opening, quick closing
T	Mains voltage: 220/240 V AC, 50/60 Hz
Q	Mains voltage: 120 V AC, 50/60 Hz
K	Mains voltage: 24 V DC
3	Terminal connection box, IP 54
1	Screw plug at the inlet
3	Screw plug at the inlet and outlet
D	With flow adjustment
M	Suitable for biologically produced methane
V	Viton valve disc seal
Z	With rolling diaphragm

6 Project planning information

6.1 Installation

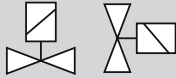

Installation position: black solenoid actuator in the vertical position or tilted up to the horizontal, not upside down.

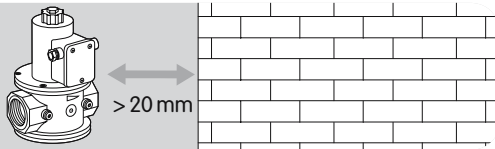

The gas solenoid valve VG must not be in contact with masonry. Minimum clearance 20 mm.

Do not store or install the unit in the open air.

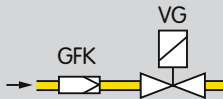

Sealing material and dirt, e.g. thread cuttings, must not be allowed to get into the valve housing.

Install a filter (GFK) upstream of every system.



The solenoid actuator heats up during operation. Surface temperature approx. 85°C (approx. 185°F) pursuant to EN 60730-1 at 10% overvoltage and an ambient temperature of 25°C (77°F).

6.2 Wiring

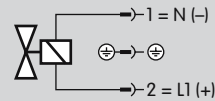

Wiring to EN 60204-1.

7 Accessories

7.1 Pressure test point

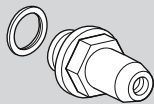

Test point to check the inlet pressure p_u and outlet pressure p_d .

Scope of delivery: 1 x test point with 1 flat seal.

Order No.	Pressure test point
74912868	G1/4 aluminium /B

7.2 Plug with socket



Plug with socket to EN 175301-803.

Order No.	
74923085	Plug + LED VG 15-40/32 230/115V /B
74923087	Plug + LED VG 15-40/32 24V /B
74923086	Plug + LED VG 40-65 230/115V /B
74923088	Plug + LED VG 40-65 24V /B

8 Technical data

Gas types: natural gas, town gas, LPG (gaseous), biologically produced methane (max. 0.1 %-by-vol. H₂S) – VG 6 – 15/10 and VG..M versions only – or clean air; other gases on request. The gas must be dry in all temperature conditions and must not contain condensate.

Opening time:

VG..N: quick opening, 0.5 s.

VG..L: slow opening, 10 s.

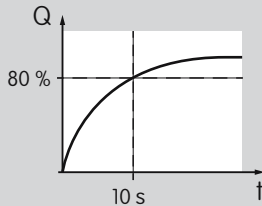

Closing time:

VG..N, VG..L < 1 s.

Ambient temperature:

-20 to +60°C, no condensation permitted.

Storage temperature: -20 to +40°C.

Safety valve:

Class A, Group 2 pursuant to EN 13611 and EN 161.

Mains voltage:

220/240 V AC, +10/-15%, 50/60 Hz,

120 V AC, +10/-15%, 50/60 Hz,

24 V DC, +10/-15%.

Electrical connection of VG 6 – 15/10:

- plug with socket to EN 175301 – 803.

Electrical connection of VG 15 – 40/32:

- plug with socket to EN 175301-803, available as an accessory,

- cable gland: PG 11,

- connection terminal: 2.5 mm².

Electrical connection of VG 40 – 65:

- plug with socket to EN 175301-803, available as an accessory,

- cable gland: PG 13.5,

- connection terminal: 2.5 mm².

Enclosure: IP 54.

Duty cycle: 100%.

Power factor of the solenoid coil: $\cos \varphi = 1$.

Solenoid coil insulation: class F insulating material.

Switching frequency:

VG..N: max. 30/min.

VG..L: there must be a period of 20 seconds between switching off and on again so that the damping is fully effective.

Valve housing: aluminium,

valve disc: NBR.

Internal thread: Rp to ISO 7-1.

Flange: ISO 7005 (DN 65 to DIN 2501), PN 16.

8.1 Dimensions of VG 6 to 15/10

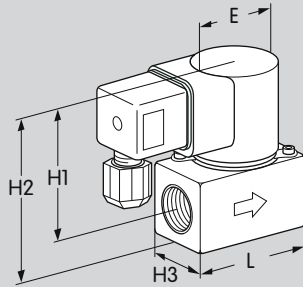

Data table

Type	Dimensions							p_u max. mbar	P 220 V AC 120 V AC 24 V DC VA/W	P 240 V AC VA/W	Weight g
	DN	Connection	L mm	H1 mm	H2 mm	H3 mm	E mm				
VG 6K03G	6	M1 2 x 1	53	63	76	26	35	360	8	9.5	400
VG 6K05	6	M1 2 x 1	53	63	76	26	35	500	8	9.5	400
VG 6R05	6	Rp 1/8	53	63	76	26	35	500	8	9.5	400
VG 8R03G	8	Rp 1/4	53	63	76	26	35	360	8	9.5	400
VG 8R05	8	Rp 1/4	53	63	76	26	35	500	8	9.5	400
VG 8R18	8	Rp 1/4	53	63	76	26	35	1800	8	9.5	400
VG 10R01	15	Rp 3/8	60	66	82	32	35	100	8	9.5	450
VG 15/10R01	15	Rp 1/2	71	66	82	32	35	100	8	9.5	450
VG 15/10R01G	15	Rp 1/2	71	66	82	32	35	100	8	9.5	450

8.2 Dimensions of VG 15 to 40/32

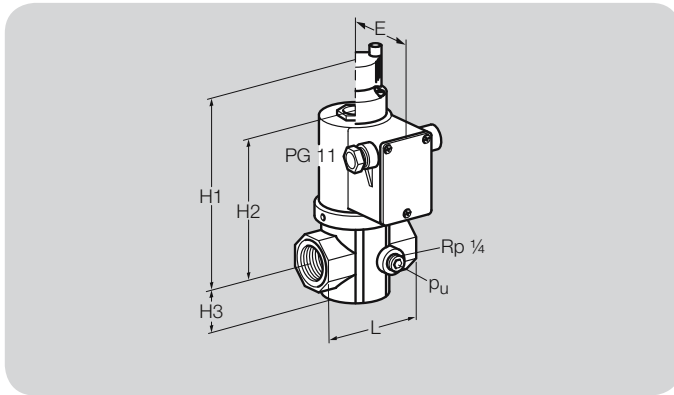

Data table

Type	Dimensions							p ₀ max. mbar	P		Weight kg
	DN	Connection	L mm	H1 mm	H2 mm	H3 mm	E mm		220 V AC 120 V AC 24 V DC VA/W	240 V AC VA/W	
VG 15R02..	15	Rp 1/2	71	161	112	24	56	200	32	38	1.26
VG 15R03..	15	Rp 1/2	71	161	112	24	56	360	32	38	1.26
VG 15/12R18..	15	Rp 1/2	71	–	112	24	61	1800	31	37	1.58
VG 20R03..	20	Rp 3/4	91	175	126	33	66	360	36	42	2.25
VG 25R03..	25	Rp 1	91	175	126	33	66	360	36	42	2.25
VG 25/15R18..	25	Rp 1	91	–	126	33	66	1800	36	42	2.25
VG 40/32R02..	40	Rp 1 1/2	128	194	145	39	66	200	36	42	2.80

8.3 Dimensions of VG 40 to 65

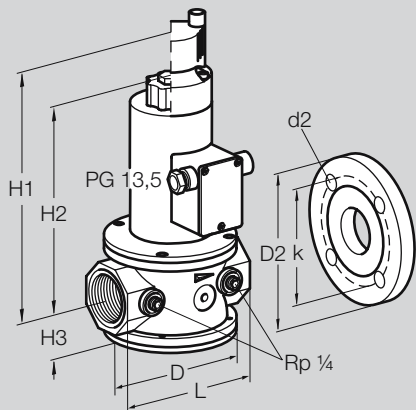

Data table

Type	Dimensions							Flange		Hole		p _v max. mbar	P		Weight kg
	DN	Conne- ction	L mm	D mm	H1 mm	H2 mm	H3 mm	D2 mm	k mm	d2 mm	No.		220 V AC 120 V AC 24 V DC VA/W	240 V AC VA/W	
VG 40R03..	40	Rp 1½	150	129	280	210	51	–	–	–	–	200	73	86	7.1
VG 40/33R10..	40	Rp 1½	150	129	280	210	51	–	–	–	–	1000	73	86	7.1
VG 40/33F10..	40	40	200	129	280	210	51	150	110	18	4	1000	73	86	8.8
VG 50R03..	50	Rp 2	180	157	291	221	62	–	–	–	–	360	85	99	12.8
VG 50F03..	50	50	230	157	291	221	62	165	125	18	4	360	85	99	14.8
VG 50/39R10..	50	Rp 2	180	157	–	221	62	–	–	–	–	1000	85	99	12.8
VG 50/39F10..	50	50	230	157	–	233	62	165	125	18	4	1000	85	99	14.8
VG 65F02..	65	65	290	183	303	233	74	185	145	18	4	200	85	99	16.3

9 Maintenance cycles

At least once a year, twice a year in the case of biologically produced methane.

Feedback

Finally, we are offering you the opportunity to assess this "Technical Information (TI)" and to give us your opinion, so that we can improve our documents further and suit them to your needs.

Clarity

- Found information quickly
- Searched for a long time
- Didn't find information
- What is missing?
- No answer

Comprehension

- Coherent
- Too complicated
- No answer

Scope

- Too little
- Sufficient
- Too wide
- No answer



Use

- To get to know the product
- To choose a product
- Planning
- To look for information

Navigation

- I can find my way around
- I got "lost"
- No answer

My scope of functions

- Technical department
- Sales
- No answer

Remarks

(Adobe Reader 7 or higher required)
www.adobe.com



Contact

Elster GmbH
Postfach 2809 · 49018 Osnabrück
Strothweg 1 · 49504 Lotte (Büren)
Germany
T +49 541 1214-0
F +49 541 1214-370
info@kromschroeder.com
www.kromschroeder.com

The current addresses of our international agents are available on the Internet:
www.kromschroeder.de/index.php?id=718&L=1

We reserve the right to make technical modifications in the interests of progress.
Copyright © 2015 Elster GmbH
All rights reserved.